



# DNH

HEAD OFFICE, NORWAY  
DNH AS

Phone..... + 47 35 98 56 00  
Fax..... + 47 35 98 56 10  
E-mail..... dnh@dnh.no  
Web-Site..... www.dnh.no

ENGLAND

DNH WW Ltd  
Phone..... + 44 1908 275 000  
Fax..... + 44 1908 275 100  
E-mail..... dnh@dnh.co.uk

GERMANY

DNH GmbH  
Phone... + 49 040 6569 30-0  
Fax..... + 49 040 6569 30-30  
E-mail..... dnh@dnh.de

USA

DNH Speakers Inc  
Phone..... + 1 484 494 5790  
Fax..... + 1 484 494 5793  
E-mail..... dnh@dnhspeakers.com

ISO 9001 CERTIFIED

## Aqua-30

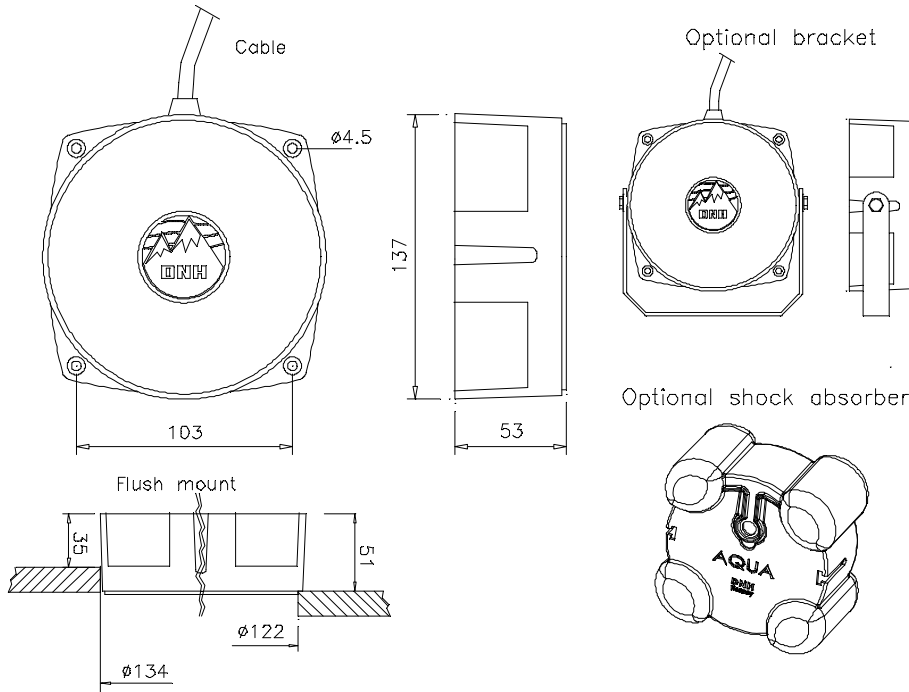

Sound pressure levels at 1W/1m under water

SPL vs Freq

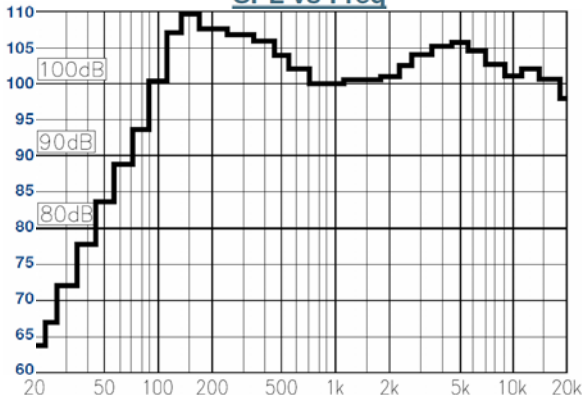

Specifications

Material / Color	ABS / NCS 1070-B, (Blue)
Mounting	4 screws
Termination	Cable, 5 m
Weight w/transformer	2,2 kg
IP-rating	68
Max. / min. amb. temp	90°C / -20°C
Rated / max. power	20 W / 30 W
SPL 1W/1m	105 dB
SPL rated power	118 dB
Effective freq. range	80 – 20000 Hz
Dispersion (-6dB) 1kHz / 4kHz	180° / 180°
Directivity factor, Q	NA
Options	Impedances, colors, labels

### Installation, Operation and Maintenance Procedures

- Use 4 screws for mounting on wall or alternative bracket system.
- When mounting with optional bracket, use the slit on each side to connect the bracket to the loudspeaker.
- Cable termination code: Green/yellow: Ground Brown: (+). Blue: (-)
- Recommended installation deep 0,5m to 2m.
- Typical sound coverage for Aqua-30 is 200 m<sup>2</sup>.
- Warning, this loudspeaker generates very high sound pressures even when driven at low power.
- For optimum performance, always use the correct voltage / power and operate within the frequency limits as stated.
- Do not open loudspeaker when energized.
- This loudspeaker is supplied with a 2 year warranty against defective workmanship.

DNH reserves the right to alter specifications without notice

