



# DNH

HEAD OFFICE, NORWAY

**DNH AS**

Phone..... + 47 35 98 56 00

Fax..... + 47 35 98 56 10

E-mail..... dnh@dnh.no

Web-Site..... www.dnh.no

ENGLAND

**DNH WW Ltd**

Phone..... + 44 1908 275 000

Fax..... + 44 1908 275 100

E-mail..... dnh@dnh.co.uk

GERMANY

**DNH GmbH**

Phone... + 49 040 6569 30-0

Fax..... + 49 040 6569 30-30

E-mail..... dnh@dnh.de

## PROB-620(T)

USA

**DNH Speakers Inc**

Phone..... + 1 484 494 5790

Fax..... + 1 484 494 5793

E-mail..... dnh@dnhspeakers.com

ISO 9001 CERTIFIED

CIRCUIT DIAGRAM

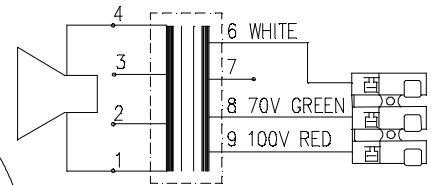

Rec. ceiling hole:  $\varnothing$  170mm

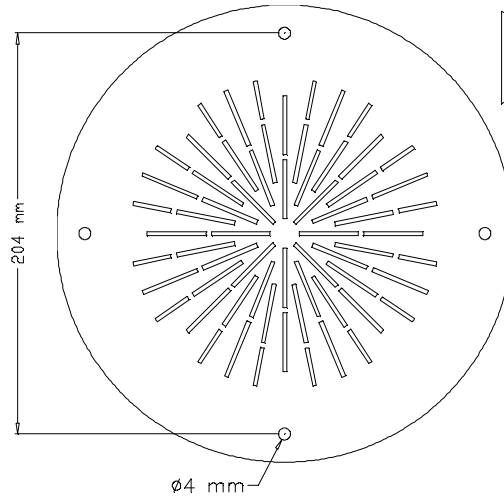
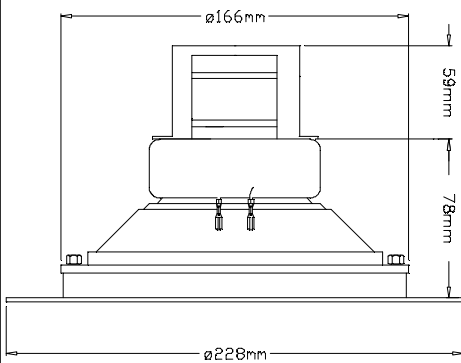

Secondary nominal tapings

|       |        |
|-------|--------|
| 1 : 4 | 30,0 W |
| 1 : 3 | 15,0 W |
| 2 : 4 | 10,0 W |
| 1 : 2 | 7,5 W  |
| 3 : 4 | 3,5 W  |
| 2 : 3 | 2,0 W  |

Sound pressure levels at 1W/1m

SPL vs Freq

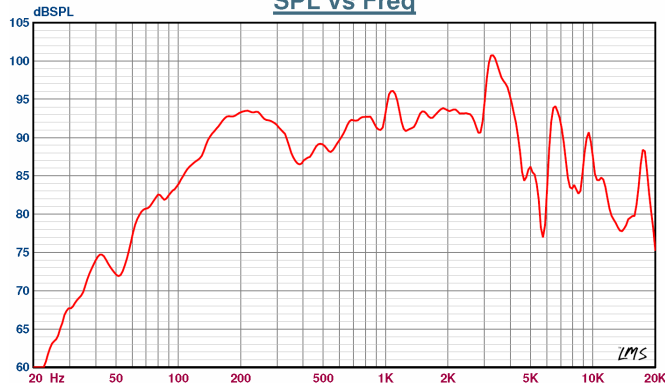

Specifications

|                               |                            |
|-------------------------------|----------------------------|
| Material / Color              | Aluminum / RAL 9010        |
| Mounting                      | 4 Screws                   |
| Termination                   | Spring clamp               |
| Weight w/transformer          | 1,7 kg                     |
| IP-rating                     | NA                         |
| Max. / min. amb. temp         | 90°C / -20°C               |
| Rated / max. power            | 30 W / 50 W                |
| SPL 1W/1m                     | 90 dB                      |
| SPL rated power               | 105 dB                     |
| Effective freq. range         | 60 – 20000 Hz              |
| Dispersion (-6dB) 1kHz / 4kHz | 130° / 50°                 |
| Directivity factor, Q         | NA                         |
| Options                       | Impedances, colors, labels |

### Installation, Operation and Maintenance Procedures

- Connect cable to terminal.
- Select required tapping.
- Install loudspeaker grill to wall/ceiling by 4 screws.
- For optimum performance, always use the correct voltage / power and operate within the frequency limits as stated.
- Do not open loudspeaker when energized.
- This loudspeaker is supplied with a 2 year warranty against defective workmanship.

DNH reserves the right to alter specifications without notice

