



DNH

HEAD OFFICE, NORWAY

DNH AS

Phone..... + 47 35 98 56 00

Fax..... + 47 35 98 56 10

E-mail..... dnh@dnh.no

Web-site..... www.dnh.no

ENGLAND

DNH WW Ltd

Phone..... + 44 1908 275 000

Fax..... + 44 1908 275 100

E-mail..... dnh@dnh.co.uk

GERMANY

DNH GmbH

Phone... + 49 040 6569 30-0

Fax..... + 49 040 6569 30-30

E-mail..... dnh@dnh.de

USA

DNH Speakers Inc

Phone..... + 1 484 494 5790

Fax..... + 1 484 494 5793

E-mail..... dnh@dnhspeakers.com

HPS-6

ISO 9001 CERTIFIED

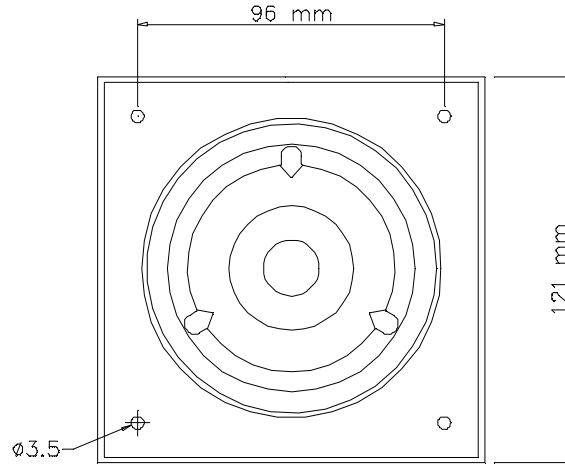
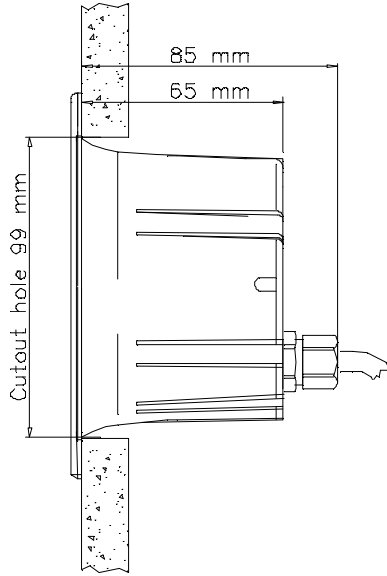

Sound pressure levels at 1W/1m

SPL vs Freq

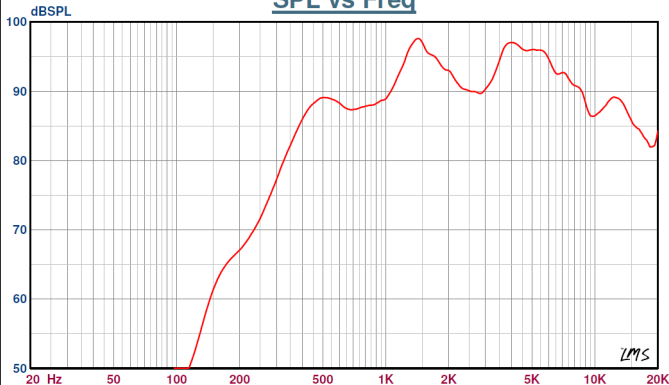

Specifications

Material / Color	Polyamide UL94 V0 / RAL 7035
Mounting	Insertion
Termination	Cable, 0,5m
Weight w/transformer	0,35 kg
IP-rating	67
Max. / min. amb. temp	110°C / -40°C
Rated / max. power	6 W / 15 W
SPL 1W/1m	100 dB
SPL rated power	107 dB
Effective freq. range	300 – 20000 Hz
Dispersion (-6dB) 1kHz / 4kHz	NA
Directivity factor, Q	NA
Options	Impedances, colors, labels

Installation, Operation and Maintenance Procedures

- Fasten loudspeaker to wall or ceiling with 4 screws, cut out hole according to drawing.
- HPS-6 is delivered with cable and the cable should be terminated in a suitable junction box.
- For optimum performance, always use the correct voltage / power and operate within the frequency limits as stated.
- Do not open loudspeaker when energized.
- This loudspeaker is supplied with a 2 year warranty against defective workmanship.

DNH reserves the right to alter specifications without notice

