



# DNH

HEAD OFFICE, NORWAY

**DNH AS**

Phone..... + 47 35 98 56 00

Fax..... + 47 35 98 56 10

E-mail..... dnh@dnh.no

Web-site..... [www.dnh.no](http://www.dnh.no)

ENGLAND

**DNH WW Ltd**

Phone..... + 44 1908 275 000

Fax..... + 44 1908 275 100

E-mail..... dnh@dnh.co.uk

GERMANY

**DNH GmbH**

Phone... + 49 040 6569 30-0

Fax..... + 49 040 6569 30-30

E-mail..... dnh@dnh.de

USA

**DNH Speakers Inc**

Phone..... + 1 484 494 5790

Fax..... + 1 484 494 5793

E-mail..... dnh@dnhspeakers.com

ISO 9001 CERTIFIED

## BIVEP-6(T)

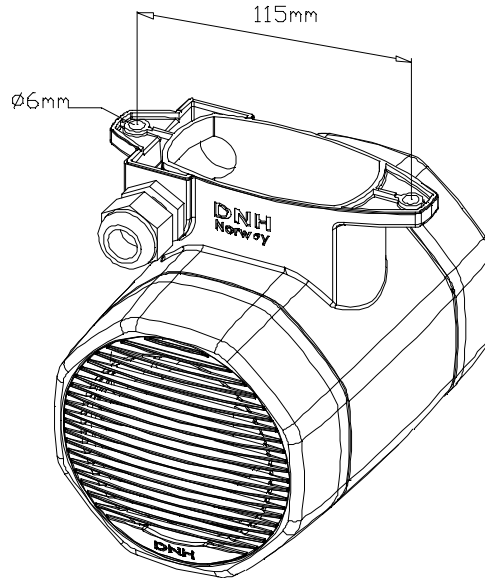
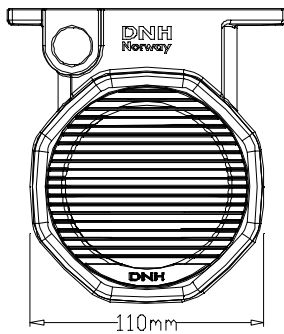
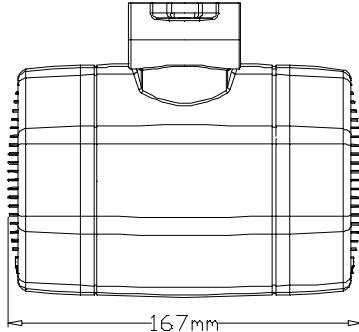

1xM20 blinding plug  
1xM20 gland

Transformer:

Combined

70/100Volt line

White : Red 100 V

White : Green 70 V

Secondary nominal  
tappings:

C : 6 6,0 W

C : 3 3,0 W

C : 1,5 1,5 W

C : 0,5 0.5 W

Sound pressure levels at different frequencies at 1W/1m

### SPL vs Freq

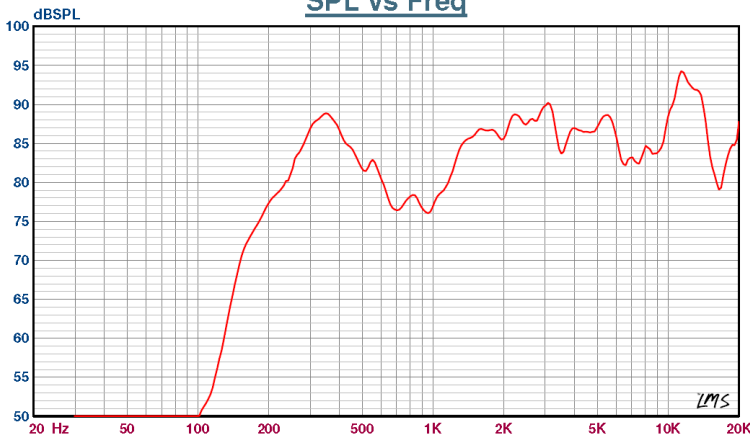

Material / Color ..... ABS / RAL 7035  
 Mounting ..... Foot bracket  
 Termination ..... Internal screw terminals  
 Weight ..... 0,94 kg  
 IP-rating ..... 44  
 Max. / min. amb. temp ..... 90 °C / -40 °C  
 Rated / max. power ..... 6 W / 10 W  
 SPL 1W/1m ..... 87 dB  
 SPL rated power ..... 94 dB  
 Effective freq. range ..... 155 – 20000 Hz  
 Dispersion (-6dB) 1kHz / 4kHz ..... ° / °  
 Directivity factor, Q .....  
 Options ..... Impedances, colors, labels

## Installation, Operation and Maintenance Procedures

- When mounting the loudspeaker please ensure that it is re-assembled in the same manner in which it was received. Fasten footbracket. Mount cable through cable gland and connect cable to the fused ceramic terminal.
- To open the loudspeaker, turn the front gently counter clockwise and pull. To close the loudspeaker, align the two marks on the front and rear parts and turn the front gently clockwise.
- For optimum performance, always use the correct voltage / power and operate within the frequency limits as stated.
- Do not open loudspeaker when energized.
- This loudspeaker is supplied with a 2 year warranty against defective workmanship.



DNH reserves the right to alter specifications without notice

Rev. 21.10.2011